



Chloride™
Power to Protect

INPUT POWER FACTOR and TOTAL HARMONIC CURRENT DISTORTION ON SCR-BASED INDUSTRIAL UPS SYSTEMS

Understanding the relation between input PF and THDi

Introduction

Electrical installations within industrial environments are subject to disturbances than are not present in other commercial operation conditions (telecom, public network...). Voltage distortion, spikes, noise, sags, swells are regularly recorded on the industrial electrical networks. Indeed, these perturbations are generated by the devices connected to the industrial network itself (motor starter, valve closing/opening, etc.).

In order to ensure power quality and continuity for industrial processes, DC and AC UPS (Uninterruptible Power Systems) are installed between the main distribution panel and the critical loads. Their main functions are to keep supplying the load in case of mains power failure and to act as a filter to prevent all upstream perturbations to reach the downstream loads.

SCR (Silicon Controlled Rectifier), most commonly known as thyristor rectifier, is a proven technology that is used in industrial battery chargers, industrial AC and DC UPS systems. It has no equivalent in robustness, reliability over time and it has widely proven to be the best fit to overcome all those disturbances and to guarantee a perfect load protection.

However, the reliability for the load is no longer the only focus. Today, the DC and AC UPS market shows an increasing interest on increasing the input power factor (PF) and on reducing the input total harmonic distortion (THDi). Both factors have a direct impact on the apparent power S consumption (expressed in kVA) and on the total RMS (Root Mean Square) value of the current at the input side. As these two factors may lead to the overheating of the upstream electrical network, it requires to oversize the cables, to increase the ratings of the upstream protections, to oversize the upstream transformers and the generators.

The purpose of this paper is to help understand the interaction between the input Power Factor (PF) and the total harmonic current distortion (THDi), particularly on the input of an SCR-based rectifier/battery charger or industrial uninterruptible power supply system. It is not aimed at describing the different technologies and solutions to improve those factors but more to help the readers figure out the close relationship between these two important factors and why, in some cases, improving the PF and reducing the THDi may become a tough challenge to achieve with SCR technology.

1 Definitions

First, let's look at the important definitions.

1.1 Displacement power factor DPF ($\cos \phi$)

EXTRACT FROM IEC62040-3:2011:

3.3.21 Displacement power factor

Displacement component of the power factor; ratio of the active power of the fundamental wave to the apparent power of the fundamental wave.

END OF EXTRACT

In AC electrical systems and except in the presence of pure resistive loads, there is an angle displacement ϕ between the voltage and the current. This phase displacement has a big impact on the active power available for the load. The displacement power factor is also known as the cosine ϕ (or $\cos \phi$).

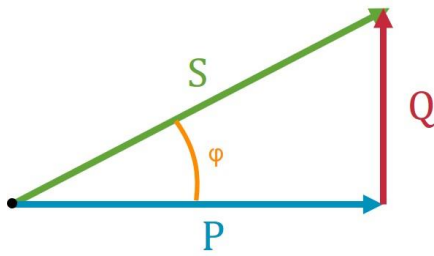

$$P(W) = U_1 \cdot I_1 \cdot \cos \phi \quad (1)$$

$$S(VA) = U_1 \cdot I_1$$

$$Q(VAR) = U_1 \cdot I_1 \cdot \sin \phi$$

Consequently:

$$P(W) = S(VA) \cdot \cos \phi$$

Therefore:

$$\cos \phi = \frac{P(W)}{S(VA)}$$

From the definition of the standard, we can see that the Displacement power factor ($\cos \phi$) consider only the fundamental waves (50 or 60Hz). Only the fundamental waves provides real (effective) power. Therefore, the $\cos \phi$ only consider sinusoidal waveforms.

One of the main interests of knowing the $\cos \phi$ of an electrical device (i.e. knowing the phase displacement between fundamental waves of the voltage and current of this device) is to be able to calculate the compensation of reactive power that may be necessary to improve the $\cos \phi$ and therefore to provide a more effective Apparent Power S to this device.

1.2 Power Factor (PF)

EXTRACT FROM IEC62040-3:2011:

3.3.19 Power factor

ratio of the absolute value of the active power P to the apparent power S :

$$\lambda = \frac{|P|}{S}$$

END OF EXTRACT

In AC electrical systems, the power factor is also the ratio between the active power P , expressed in Watts (W) and the apparent power S , expressed in Volt-Ampere (VA).

One important point though is that the power factor does not only consider the fundamental waves but also the other ranks. In other words, the power factor also considers the harmonic content of the signal.

A value of PF below unity means that the voltage and current waveforms are not in phase.

$$P(W) = U_1 \cdot I_1 \cdot \cos \phi$$

$$S(VA) = U_{RMS} \cdot I_{RMS} \quad (2)$$

Therefore:

$$PF = \frac{P(W)}{S(VA)} \quad (3)$$

One of the main interests of knowing the PF of an electrical device is to be able to size the upstream network according to the current needed by the device and to the harmonic currents generated by the device.

1.3 Input power factor

EXTRACT FROM IEC62040-3:2011:

3.4.3 Input power factor

Ratio of the input active power to the input apparent power with the UPS operating in normal mode, at rated input voltage, rated load and with a fully charged energy storage system.

END OF EXTRACT

The input power factor of a battery charger or of an AC UPS system is to be considered for the most frequent state of the system, i.e. when the battery is fully charged, and all the values are nominal.

1.4 Linear loads

EXTRACT FROM IEC62040-3:2011:

3.2.4 Linear load

Load where the current drawn from the supply is defined by the relationship:

$$I = \frac{U}{Z}$$

Where

I is the load current

U is the supply voltage

Z is the constant load impedance

NOTE: Application of a linear load to a sinusoidal voltage results in a sinusoidal current.

END OF EXTRACT

In a pure resistive AC circuit, like a heater, the voltage and current are in phase. In other words, there is no phase displacement factor between the current and the voltage on a resistive load.

Consequently:

For linear loads: $PF = \cos \phi$.

1.5 Non-linear loads

EXTRACT FROM IEC62040-3:2011:

3.2.5 Non-linear load

Load where the parameter Z (load impedance) is no longer a constant but is a variable dependent on other parameters, such as voltage or time.

END OF EXTRACT

In the presence of reactive loads in AC electrical systems, such as capacitors or inductors, the current and voltage waveforms show a phase displacement.

In addition to the fundamental current I_{H1} , non-linear loads generate harmonics.

For example, SCR-based AC or DC UPS (uninterruptible power supply) are non-linear loads: their input current is not a pure sinewave.

Consequently:

For non-linear loads: $PF \neq \cos \phi$.

1.6 Total harmonic distortion THD

EXTRACT FROM IEC62040-3:2011:

3.3.26 Total harmonic distortion

Ratio of the r.m.s. value of the harmonic content of an alternating quantity to the r.m.s. value of the fundamental component quantity

END OF EXTRACT

1.7 Individual harmonic distortion

EXTRACT FROM IEC62040-3:2011:

3.3.27 Individual harmonic distortion

Ratio of the r.m.s. value of the harmonic content of an alternating quantity to the r.m.s. value of the fundamental component quantity

END OF EXTRACT

1.8 Harmonic components

EXTRACT FROM IEC62040-3:2011:

3.3.28 Harmonic components

Components of the harmonic content as expressed in terms of the order and r.m.s. values of the Fourier series terms describing the periodic function

END OF EXTRACT

A harmonic is a component of a periodic waveform having a frequency that is a multiple of the fundamental H_1 frequency, 50 or 60 Hz in power supply networks.

For example, the harmonic 7, noted H_7 is 350 Hz (7 x 50 Hz) and is the 7th order harmonic of the fundamental frequency.

1.9 Harmonic content

EXTRACT FROM IEC62040-3:2011:

3.3.29 Harmonic content

Quantity obtained by subtracting the fundamental component from an alternating quantity

END OF EXTRACT

1.10 Input harmonic current distortion

EXTRACT FROM IEC62040-3:2011:

3.4.7 input current distortion

Maximum input current harmonic distortion, in normal mode

END OF EXTRACT

The root-mean square value of the current I_{rms} is the square root of the quadratic sum of all the harmonics (including the fundamental H_1). It equals to:

$$I_{RMS} = \sqrt{\frac{1}{T} * \int_0^T i(t)^2}$$

The I_{rms} current can also be expressed as:

$$I_{RMS} = \sqrt{I_1^2 + \sum_{n \geq 2} I_n^2} = I_1 \sqrt{1 + \sum_{n \geq 2} \left(\frac{I_n}{I_1}\right)^2}$$

The Total Current Harmonic Distortion THD_i equals to:

$$THD_i(\%) = \frac{\sqrt{\sum_{n \geq 2} I_n^2}}{I_1} \quad (4)$$

Let's now zoom on an SCR-based battery charger or on a UPS system with an integrated SCR rectifier:

For information, at the input of a SCR's rectifier (battery charger) the harmonics are due to the harmonic currents generated by the rectifier; Basically these harmonics depends on the topology of the rectifier used. A six-pulse rectifier generates 5th and 7th harmonics and their multiples (n.pulses +1 and n.pulses-1), a twelve pulses rectifier generates 11th and 13th harmonics and their multiples.

The I_{RMS} current can be written as follow:

$$I_{RMS} = I_1 \sqrt{1 + THD_i^2} \quad (5)$$

SUMMARY

- The $\cos \phi$ is the phase displacement between the voltage and the current
- $PF = \cos \phi$ (DPF) only when the voltage and current are sinusoidal.
- In presence of non-linear loads, $PF < \cos \phi$
- The PF takes into account the current harmonic distortion THDi

2 Relation between THDi and Power Factor

2.1 In general

Let us first prove the interdependency between THDi and Power Factor.

By the definitions given earlier:

- According to **(1)**, the expression of the active power P (the power that is real (effective) for the load) is:

$$P(W) = U_1 \cdot I_1 \cdot \cos \varphi$$

- According to **(2)**, the expression of the apparent power S (the power that is necessary for the load to be able to work at the real power level) is:

$$S(VA) = U_{RMS} \cdot I_{RMS}$$

According to **(5)**, the expression of the I_{RMS} current (the Root Mean Square value of the current that is necessary for the load) is:

$$I_{RMS} = I_1 \sqrt{1 + THD_i^2}$$

- According to **(3)**, the expression of the power factor PF is:

$$PF = \frac{P(W)}{S(VA)}$$

The above formulas give:

$$PF = \frac{P(W)}{S(VA)} = \frac{U_1 \cdot I_1 \cdot \cos \varphi}{U_{RMS} \cdot I_1 \sqrt{1 + THD_i^2}}$$

We can see from the above that the PF, the $\cos \varphi$ and the THDi are linked together.

Moreover, and considering that the voltage harmonic distortion THDv at the input side is very low, we can assert that:

$$U_{RMS} \approx U_1$$

Consequently, the preceding formula becomes:

$$PF = \frac{P(W)}{S(VA)} = \frac{U_1 \cdot I_1 \cdot \cos \varphi}{U_1 \cdot I_1 \sqrt{1 + THD_i^2}}$$

Thus:

$$PF = \frac{\cos \varphi}{\sqrt{1 + THD_i^2}} \quad (6)$$

SUMMARY

The above demonstration as well as the formula (6) prove the following:

- There is a strong interdependency between the PF, the $\cos \varphi$ and the THDi
- When the THDi increases, the power factor decreases
- In presence of harmonic currents THDi, the power factor is lower than the $\cos \varphi$

2.2 Applied to SCR-based UPS systems

Let us now see the relation between Harmonic current distortion (THDi) and Power Factor (PF) on an SCR-based rectifier, battery charger or UPS system.

The formula (5) allows to highlight 2 important facts that may become paradoxal in many cases.

2.2.1 If the THDi percentage value needs to be reduced

When the THDi percentage value needs to be reduced on an SCR-based system, the most common solutions are:

- A 6-pulse rectifier. This type of rectifier shows a THDi percentage value of around 30-35%.
- A 12-pulse rectifier. This type of rectifier shows a THDi percentage value of around 10-14%.
- A 12-pulse rectifier plus a passive filter. This type of solution shows a THDi percentage value of around 5-6%.

In the latest solution, the system is most commonly a 12-pulse SCR rectifier on which a passive filter is added. The passive filter is in the form of an AC choke between the source and the SCR rectifier. However, this choke brings a voltage drop that needs to be compensated on the secondary of the rectifier transformer so that the rectifier is still able to operate at the required voltage on its secondary circuit. It implies a transformer with a higher secondary voltage which deteriorates the $\cos \phi$.

We see from the above that the reduction of the THDi percentage value leads to the degradation of the input $\cos \phi$, and therefore to the implicit reduction of the input power factor PF.

Yet, when the PF (or $\cos \phi$) is degraded, there is a way to improve it. On an SCR rectifier, the best solution to improve the input PF (or $\cos \phi$) is achieved by adding a capacitor bank on the network side, upstream the rectifier. This brings the benefit of increasing the input $\cos \phi$ and therefore the input PF. However, this solution has a main drawback:

- The network harmonics could increase due to the interaction between the network impedance and the capacitor bank (negative effect on THDi, resonance, see paragraph 3).

SUMMARY

- Reducing the input THDi percentage value on an SCR-based rectifier has a negative impact on the input power factor.
- A capacitor bank added upstream the SCR rectifier allows to increase the input power factor but may also generate a resonance effect if these capacitors are unluckily tuned on some unknown or unidentified network harmonics.

2.2.1 If the power factor needs to be increased

When the $\cos \phi$ needs to be improved on an SCR-based system, another paradox may appear.

Let's consider a rectifier that operates at a specific point of active power, i.e. at specific constant values of AC input voltage, DC output voltage and DC output current. At this specific point of active power, this rectifier generates a constant THDi ratio that is not related to the input $\cos \phi$.

We can consider that this rectifier is in the nominal conditions, as per the definition of the input power factor given in paragraph 1.3 of this document.

Because $P(W) = U_1 \cdot I_1 \cdot \cos \phi$, we can say that for this specific point of constant active power, the higher the $\cos \phi$, the lower the fundamental I_1 will be (so that P can remain constant).

Consequently, any action towards an improvement of the $\cos \phi$ (and therefore the PF) at this specific point of active power will lead to the reduction of I_1 .

But if I_1 decreases, it will mathematically lead to the increase of the percentage value of the THDi, as per formula (4) seen earlier. Indeed, the smaller the value of the fundamental I_1 with constant harmonic current values, the higher the THDi in percent will be.

Example

We consider a rectifier at a specific operating point on which we measure the relevant information. At the moment the measures are recorded, the rectifier is:

- in stabilized boost mode delivering a constant DC voltage of 441Vdc
- Delivering a constant DC current of 104A
- Supplied by a constant AC input voltage of 400Vac

The measures are recorded twice on the same rectifier, first without and then with the addition of a capacitor bank to improve the input PF.

The results are shown in the table hereafter.

	No PF correction	With PF correction
PF	0.79	0.85
I_{RMS}	91.8 A	85.75 A
I_{H1}	91.7 A	85.6 A
I_{H5}	1.2 A	1.6 A
I_{H7}	0.35 A	0.6 A
I_{H11}	3.2 A	3.2 A
I_{H13}	2.7 A	2.7 A
THDi	4.8 %	5.8 %

SUMMARY

- Increasing the input power factor has a negative impact on the THDi (%) value of the SCR-based rectifier.
- Focus shall not only be put on percentage value of the THDi, but also on the Ampere values of these harmonic currents.

From the above recordings, we note the following points:

- Harmonics I_{H5} and I_{H7} are slightly affected by the PF corrector.
- The fundamental I_{H1} is strongly reduced by the addition of the filtering capacitor bank aimed at improving the input power factor PF.
- The percentage value of THDi increases when the PF is improved, because the fundamental current I_{H1} is reduced.
- In presence of the PF corrector, the THDi percentage value increases but the individual harmonic current values do not change drastically.
- In presence of the PF corrector, the I_{RMS} value strongly decreases for the benefit of upstream cables, upstream protections, transformers, etc...

3 Basics of Power Factor correction

As we have seen previously, the purpose of improving the $\cos \phi$ (PF) is the reduction of the fundamental current I_1 , and therefore the reduction of the heat generated in the cables, input transformer or generator.

The active power of a three-phase system is:

$$P = \sqrt{3} \cdot U \cdot I_{RMS} \cdot \cos \phi$$

One simple way of improving the $\cos \phi$ (or power factor PF) is to use a capacitor bank, also called a passive PFC (Power Factor Corrector, see Figure 1).

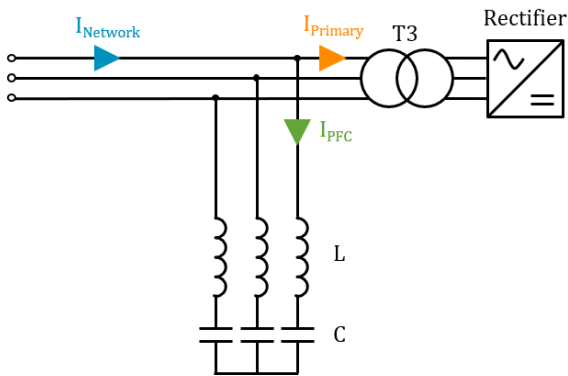

Figure 1: $\cos \phi$ corrector circuit (LC)

In all accuracy, the passive PFC should be called a “ $\cos \phi$ corrector” as its role is to introduce a current I_{PFC} (see Figure 2) in opposition to the main reactive current $I_{Primary}$ so that the reactive current value is reduced. Consequently, the $\cos \phi$ value is improved.

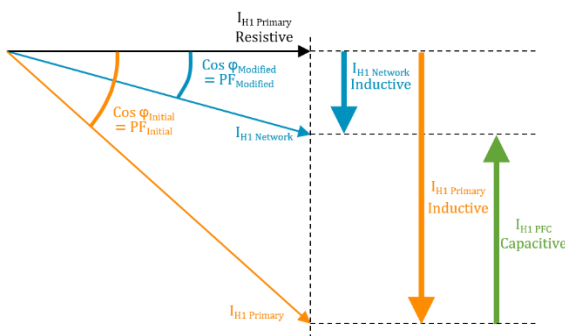

Figure 2: Fresnel diagram

In theory, the passive PFC is made of a capacitor bank.

In the reality of the industrial applications, a choke is usually added in series with each capacitor bank. The main purpose of the chokes is to avoid a resonance between the capacitors and the input impedance (made of upstream cables and transformers). The presence of the capacitors alone may potentially amplify some input network harmonic currents. This is referred to as harmonic resonance. The resonance frequency, i.e. the frequency value at which the amplification occurs, is usually low, close to the frequencies of the 5th and 13th harmonics, that are also the frequency values at which an SCR rectifier may generate harmonics.

Capacitor banks themselves are passive components and therefore do not cause harmonic currents. Still they may amplify harmonic problems. That is why the chokes in series are calculated and added in the circuit to avoid as much as possible those harmonic resonances. Nevertheless, resonances may happen at site, depending on the network impedance and on other non-linear loads supplied by the network.

Important Note

The same LC network (same electrical schematic as shown on Figure 1) can either be a harmonic filter, either a $\cos \phi$ corrector:

- As a harmonic filter, the components are calculated and **tuned to filter** a specific harmonic rank
- As a PFC (or $\cos \phi$ corrector), the components are calculated to **de-tune the LC network** so that it avoids harmonic currents from the Network to be amplified.

Conclusion

The harmonics content and the power factor are 2 important points defining power quality. As more and more emphasis is put on these two points it is important to understand the close relation between them in general, and particularly inside SCR-based (thyristor) rectifiers.

First it is important to not be confused between Displacement Power factor (DPF), also called $\cos \phi$, and Power Factor. The DPF refers to fundamental voltages and currents while the Power Factor (PF) takes into account the harmonics.

Then, as we have seen in this paper, Total Harmonic Current Distortion (THDi) and input Power Factor (PF) are so closely linked that:

- A low THDi requirement intrinsically and automatically limits the acceptable power factor value on the input of any device.
- On the contrary, a high input power factor requirement intrinsically invokes a limitation on the acceptable percentage value of THDi.

The two points above mean that it is not always possible to reach a high power factor and a low THDi simultaneously. The two values should be regarded together and not independently. In addition, should the high PF and low THDi combination be achievable on an SCR-based UPS system, one should also consider the complexity and the reliability of the power supply system. The addition of complex and less reliable passive circuits may potentially add weak points on the system. Should the passive circuit fail, the complete power supply system may be down.

Hence, power quality is not only a problem of harmonics and power factor. Reliability and Availability of the power supply come first in critical industrial applications.

4 References

IEC 62040-3:2011: Uninterruptible power systems (UPS) – Method of specifying the performance and test requirements



Chloride.com | Chloride SAS, 30 Avenue des Frères Montgolfier, 69684 Chassieu Cedex, France

T: +33 (0)4 78 40 13 56 Hello@Chloride.com

© 2022 Chloride SAS. All rights reserved. Chloride, the Chloride logo are trademarks or registered trademarks of Chloride SAS. All other names and logos referred to are trade names, trademarks or registered trademarks of their respective owners. Whilst every precaution has been taken to ensure accuracy and completeness herein, Chloride SAS assumes no responsibility for, and disclaims all liability for, damages resulting from the use of this information or for any errors or omissions. Specifications are subject to change without notice.